

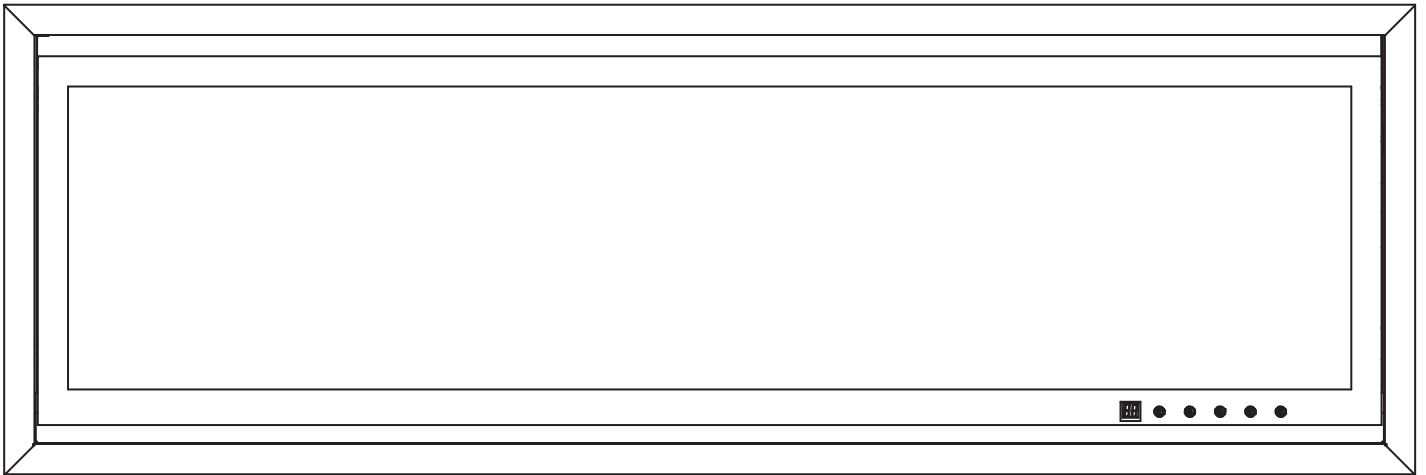

KENNEDY
FIREPLACES

Electric Fireplace

With Mounting Bracket Kit for Adjustable Installation



Owner's Manual

Model Number	Item Number
Kennedy II 42 / JR-42S	EF-WM502
Kennedy II 50 / JR-50S	EF-WM503
Kennedy II 60 / JR-60S	EF-WM504
Kennedy II 72 / JR-72S	EF-WM505



READ & SAVE THESE INSTRUCTIONS

Carefully read and review before assembling, installing, operating, or maintaining this product. Observe all safety instructions and information.

FAILURE TO FOLLOW WARNINGS & OPERATIONAL INSTRUCTIONS CONTAINED IN THIS MANUAL CAN RESULT IN PROPERTY DAMAGE OR PERSONAL INJURY

****IMPORTANT NOTICE****

For customer service & warranty issues, please contact: customer care@jrhome.com

Introduction

WARNING

- **THIS APPLIANCE IS HOT WHEN OPERATED AND CAN CAUSE SEVERE BURNS IF CONTACTED.**
- Do not operate appliance before reading and understanding operating instructions. Failure to operate appliance according to operating instructions could cause fire or injury.
- Risk of burns. Power should be turned off and the appliance allowed to cool down before servicing. To disconnect power, turn controls to off, then remove plug from outlet.
- Do not install damaged, incomplete or substitute components.
- Do not burn wood and/or other materials in this appliance.
- Young children should be carefully supervised when they are in the same room as the appliance. Toddlers, young children and others may be susceptible to accidental contact burns. A physical barrier is recommended if there are at risk individuals in the house. To restrict access to an appliance or stove, install an adjustable safety gate to keep toddlers, young children and other at risk individuals out of the room and away from hot surfaces.
- Clothing or other flammable material should not be placed on or near the appliance.
- Due to high temperatures, the appliance should be located out of traffic and away from furniture and draperies.
- Ensure you have incorporated adequate safety measure to protect infants/toddlers from touching hot surfaces.
- Even after the appliance is off, the trim, glass and/or screen will remain hot for an extended period of time.
- Check with your local hearth specialty dealer for safety screens and hearth guards to protect children from hot surfaces. These screens and guards must be securely fastened to the floor.
- Any safety screen or guard removed for servicing must be replaced prior to operating the appliance.
- It is imperative that the control compartments, circulating blower and its passageway in the appliance are kept clean. The appliance should be inspected before use and at least inspected annually by a qualified service person. Frequent cleaning may be required due to excessive lint from carpeting, bedding material, etc. The appliance area must be kept clear and free from combustible materials, gasoline and other flammable vapors and liquids.
- Under no circumstances should this appliance be modified.
- Do not use this appliance if any part has been submerged in water. Immediately call a qualified service technician to inspect the appliance and to replace any part of the control system which has been in contact with water.
- Do not operate the appliance with the glass door removed, cracked or broken. Replacement of the glass should be done by a licensed or qualified service person.
- Do not strike or slam shut the appliance glass door.
- Keep the packaging material out of reach of children and dispose of the material in a safe manner. As with all plastic bags, these are not toys and should be kept away from children and infants.
- Servicing should be done only while the appliance is disconnected from the power supply circuit.
- Always unplug appliance when not in use.
- Do not operate this appliance with a damaged cord or plug after the appliance malfunctions, has been dropped or damaged in any manner. Return appliance to authorized service facility for examination, electrical or mechanical adjustment, or repair.
- Do not use outdoors.
- Do not place appliance where it may fall into a bathtub or other water container.
- Do not run cord under carpeting. Do not cover cord with throw rugs, runners, or the like. Arrange cord away from crowded or high traffic areas and where it will not be tripped over.
- Connect to properly grounded outlets only.
- Do not insert or allow foreign objects to enter any ventilation or exhaust opening as this may cause an electric shock or fire, or damage the appliance.
- To prevent a possible fire, do not block air intakes or exhaust in any manner. Do not use on soft surfaces, like a carpet, where openings may become blocked.
- Always plug appliances directly into a wall outlet/receptacle. Never use an extension cord or relocatable power tap (outlet/power strip).
- Ensure clearances to combustibles are maintained when building a mantel or shelves above the appliance. Elevated temperatures on the wall or in the air above the appliance can cause melting, discoloration or damage to decorations, a T.V. or other electronic components.

Dimensions

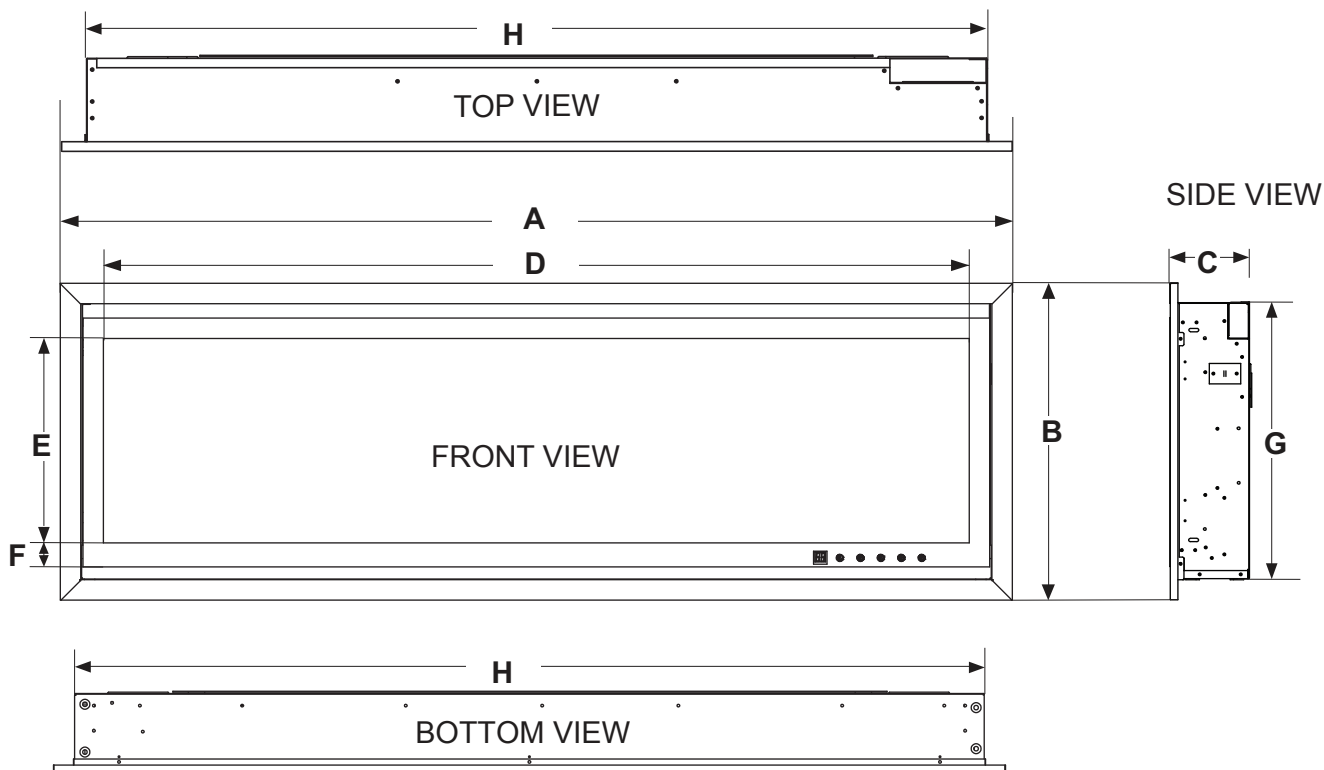

Listing Approvals

This appliance has been tested in accordance with the CSA Standards for fixed and location-dedicated electric room appliances in the United States and Canada. If you need assistance during installation, please contact your local dealer.

NOTE: This appliance must be electrically wired and grounded in accordance with local codes or, in the absence of local codes, with National Electric Code ANSI/NFPA 70-latest edition in the United States or the Canadian Electric Code, CSA C22.2 in Canada.

PRODUCT DIMENSIONS									CARTON DIMENSIONS
Model No.	A	B	C	D	E	F/F'	G	H	Width x Depth x Height
JR-42S / EF-WM502	47.0"	18.3"	4.6"	42.0"	11.8"	1.3"	16.0"	44.4"	55.12" W X 9.45" D X 24.80" H
JR-50S / EF-WM503	55.0"	18.3"	4.6"	50"	11.8"	1.3"	16.0"	52.4"	62.99" W X 9.45" D X 24.80" H
JR-60S / EF-WM504	65.0"	18.3"	4.6"	60"	11.8"	1.3"	16.0"	62.4"	73.23" W X 9.45" D X 24.80" H
JR-72S / EF-WM505	77.0"	18.3"	4.6"	72"	11.8"	1.3"	16.0"	74.4"	85.04" W X 9.45" D X 24.80" H

Model & Item No.	Net Weight	Gross Weight
JR-42S / EF-WM502	18 KGS	25 KGS
JR-50S / EF-WM503	22 KGS	30.5 KGS
JR-60S / EF-WM504	26 KGS	35 KGS
JR-72S / EF-WM505	31 KGS	42.5 KGS

Description	Electric Fireplace
Type	Built-in or Wall Mount
Voltage	120V AC
Watts	MAX 1500W
Amps	15 AMP Grounded Circuit

General Instructions

WARNING

READ THESE INSTRUCTIONS COMPLETELY BEFORE BEGINNING INSTALLATION. FAILURE TO FOLLOW THEM COULD CAUSE AN APPLIANCE MALFUNCTION RESULTING IN SERIOUS INJURY AND/OR PROPERTY DAMAGE.

ALL ELECTRIC APPLIANCES HAVE HOT AND ARCING OR SPARKING PARTS INSIDE. DO NOT USE IT IN AREAS WHERE GASOLINE, PAINT OR FLAMMABLE LIQUIDS ARE PRESENT.

THIS ELECTRIC APPLIANCE IS TESTED AND LISTED FOR USE ONLY WITH THE OPTIONAL ACCESSORIES LISTED IN THESE INSTRUCTIONS. USE OF OPTIONAL ACCESSORIES NOT SPECIFICALLY TESTED FOR THIS ELECTRIC APPLIANCE COULD VOID THE WARRANTY AND/OR RESULT IN A SAFETY HAZARD.

DO NOT OPEN. RISK OF ELECTRIC SHOCK. NO USER-SERVICEABLE PARTS INSIDE.

DO NOT USE DAMAGED ELECTRICAL CORDS.

SERVICING SHOULD BE DONE ONLY WHILE THE APPLIANCE IS DISCONNECTED FROM THE POWER SUPPLY CIRCUIT.

TO PREVENT ELECTRIC SHOCK MATCH THE WIDE BLADE OF PLUG TO WIDE SLOT OF RECEPTACLE AND FULLY INSERT.

1. Prior to plugging your appliance into an electrical outlet, verify that the house circuit breakers for the outlet are on.
2. The appliance may emit a slight, harmless odour when first used. This odour is normal and it is caused by the initial heating of internal appliance elements and will not occur again.
3. If your appliance does not emit heat, consult the operation section of this manual for further information.
4. Use with a CSA or UL certified surge protector.
5. Do not route the power cord directly underneath the appliance.





This electric appliance meets the construction and safety standards of H.U.D. for application in manufactured homes when installed according to these instructions.

As with most electronic devices, your new electric fireplace has been designed to operate at temperatures between 5°C (41°F) and 35° C (95°F). During the colder winter months, allow the fireplace to reach room temperature before turning it on

Unpacking and Testing Appliance

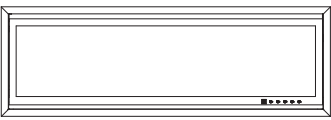
Carefully remove the appliance from the box. Prior to installing the appliance, test to make sure the appliance operates properly by plugging the power supply cord into a conveniently located 120 Volt grounded outlet.

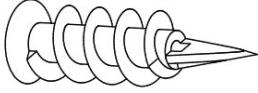
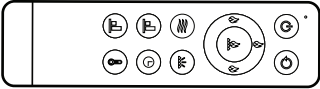
Hardware Parts List

 <p>A- Fireplace</p> <p>JR-42S x1 JR-50S x1 JR-60S x1 JR-72S x1</p>	 <p>B- Mounting Bracket</p> <p>JR-42S x1 JR-50S x1 JR-60S x1 JR-72S x1</p>	 <p>C- Wood Screws</p> <p>JR-42S x15 JR-50S x19 JR-60S x19 JR-72S x22</p>	 <p>D- Drywall Anchors</p> <p>JR-42S x 9 JR-50S x13 JR-60S x13 JR-72S x16</p>
 <p>E-Remote Control</p> <p>JR-42S x1 JR-50S x1 JR-60S x1 JR-72S x1</p>	 <p>F- Logs</p> <p>JR-42S x5 JR-50S x5 JR-60S x5 JR-72S x10</p>	 <p>G- Crystals</p> <p>JR-42S x1 Bags JR-50S x1 Bags JR-60S x1 Bags JR-72S x1 Bags</p>	

Download the JR App

Available for Android and iOS, the JR app can be used to control your WiFi-enabled fireplaces.



Smart Flame Connect



more help? <https://www.jrhome.com/app-smart-flame-connect-techsup/>

Locating Appliance

WARNING

DUE TO HIGH TEMPERATURES, THIS ELECTRIC APPLIANCE SHOULD BE LOCATED OUT OF TRAFFIC. KEEP COMBUSTIBLE MATERIALS SUCH AS FURNITURE, PILLOWS, BEDDING, PAPERS, CLOTHES AND CURTAINS AT LEAST 36" (914mm) FROM THE FRONT OF THE APPLIANCE.

NEVER LOCATE THIS ELECTRIC APPLIANCE WHERE IT MAY FALL INTO A BATHTUB OR OTHER WATER CONTAINER.

WEAR SAFETY GLOVES AND SAFETY GLASSES FOR PROTECTION DURING INSTALLATION AND MAINTENANCE.

TO PREVENT CONTACT WITH SAGGING OR LOOSE INSULATION, THE ELECTRIC APPLIANCE MUST NOT BE INSTALLED AGAINST VAPOR BARRIER OR EXPOSED INSULATION. LOCALIZED OVERHEATING COULD OCCUR AND A FIRE COULD RESULT.

DO NOT EXPOSE THE ELECTRIC APPLIANCE TO THE ELEMENTS (SUCH AS RAIN, ETC.)

Grounding Appliance

This appliance is for use on 120 Volts. The cord has a plug as shown in (A).

To disconnect appliance, turn controls to off, then remove plug from outlet.

GROUNDING METHODS

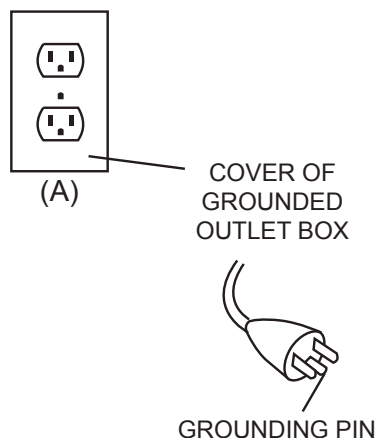

Installation

WARNING

RISK OF FIRE! THE POWER CORD MUST NOT BE PINCHED AGAINST A SHARP EDGE. SECURE CORD TO AVOID TRIPPING OR SNAGGING TO REDUCE THE RISK OF FIRE, ELECTRIC SHOCK OR PERSONAL INJURY. DO NOT RUN CORD UNDER CARPETING. DO NOT COVER CORD WITH THROW RUGS, RUNNERS OR THE LIKE. ARRANGE CORD AWAY FROM TRAFFIC AREAS AND WHERE IT WILL NOT BE TRIPPED OVER.

RISK OF FIRE! TO PREVENT A POSSIBLE FIRE, DO NOT BLOCK AIR INTAKE OR EXHAUST IN ANY MANNER. DO NOT USE ON SOFT SURFACES WHERE OPENINGS MAY BECOME BLOCKED.

RISK OF FIRE! DO NOT BLOW OR PLACE INSULATION AGAINST THE APPLIANCE.

THIS ELECTRIC APPLIANCE IS TESTED AND LISTED FOR USE ONLY WITH THE APPROVED OPTIONAL ACCESSORIES. USE OF OPTIONAL ACCESSORIES NOT SPECIFICALLY TESTED FOR THIS ELECTRIC APPLIANCE COULD VOID THE WARRANTY AND/OR RESULT IN A SAFETY HAZARD.

IF THE INFORMATION IN THESE INSTRUCTIONS IS NOT FOLLOWED EXACTLY, A FIRE OR EXPLOSION MAY RESULT CAUSING PROPERTY DAMAGE, PERSONAL INJURY OR DEATH. DO NOT STORE OR USE GASOLINE OR OTHER FLAMMABLE VAPORS IN THE VICINITY OF THIS OR ANY OTHER APPLIANCE.

THIS APPLIANCE IS HEAVY. IT IS HIGHLY RECOMMENDED THAT TWO PEOPLE INSTALL THIS APPLIANCE.

HEATER VENTS ON THE ELECTRIC APPLIANCE CANNOT, IN ANY WAY, BE COVERED AS IT MAY CREATE A FIRE HAZARD.

DO NOT RUN THE POWER CORD HORIZONTALLY, DIRECTLY BELOW THE APPLIANCE.

Your JR 42S/50S/60S/72S unit is a wall-mounted appliance. Select a suitable location that is not susceptible to moisture and is away from drapes, furniture and high traffic areas.

NOTE: Follow all National and local electrical codes.

Minimum Clearance to Combustibles

Measurements are taken from the glass front

Bottom	0"	Top	0"
Sides	0"	Top	0"
Back	0"		

Minimum Mantel Clearances

WARNING

WHEN USING PAINT OR LACQUER TO FINISH THE MANTEL, THE PAINT OR LACQUER MUST BE HEAT RESISTANT TO PREVENT DISCOLOURATION.

Adjustable Mounting Brackets and Installation Options

NOTE: It is recommended that the walls for the appliance enclosure be finished (ie. drywall) to avoid exposed insulation or vapour barriers coming in contact with the appliance. This will ensure clearance to combustibles is maintained.

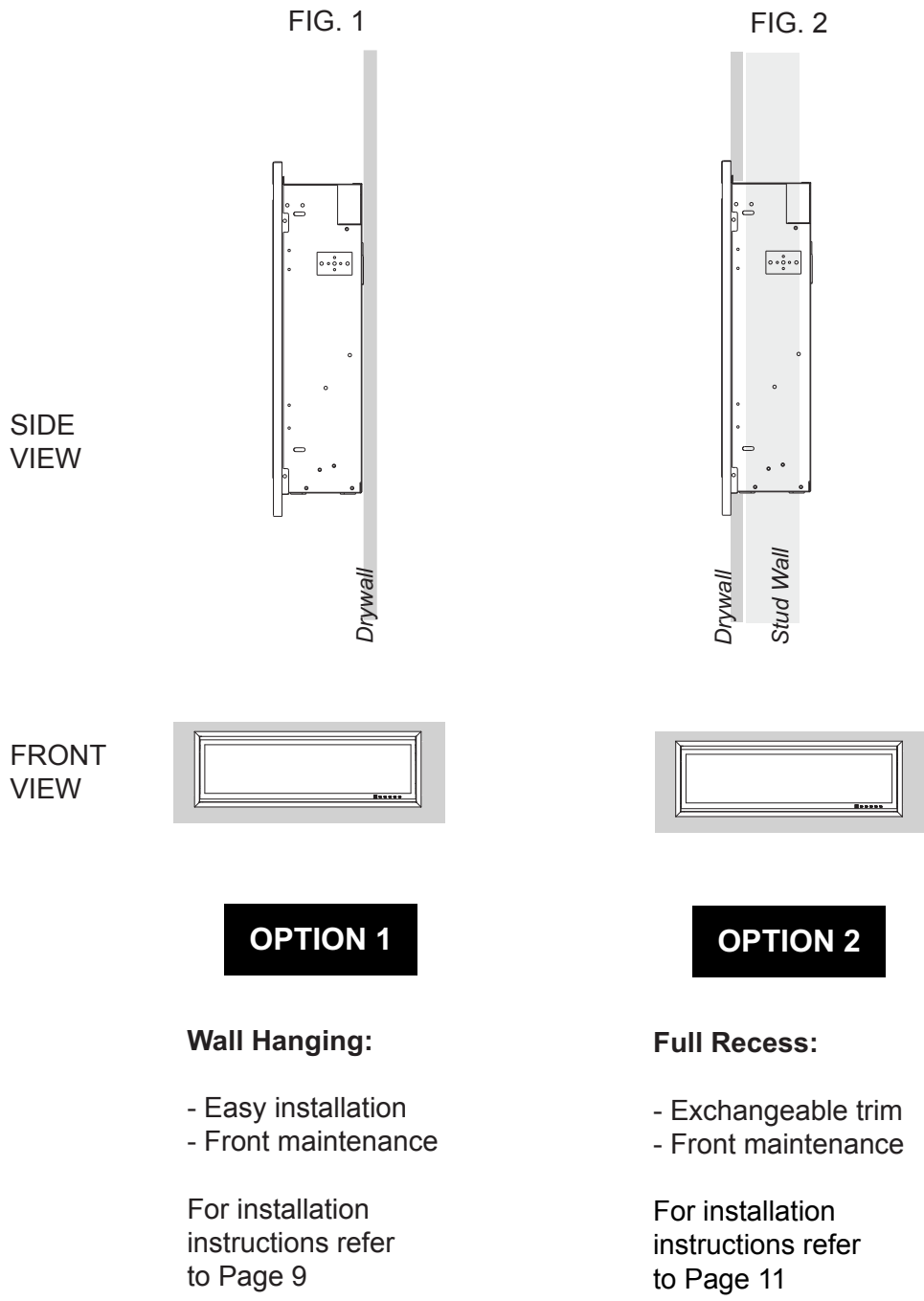

Option 1: Hanging the Appliance on the Wall

Due to the many different materials used on different walls, it is highly recommended that you consult your local builder before you install this appliance on the wall.

1. Select a location that is not prone to moisture and is located at least 36" (914mm) away from combustible materials such as curtain drapes, furniture, bedding, paper, etc.
2. Have two people hold the appliance against the wall to determine the final location.
3. Remove the bracket from the back of the unit by removing the two screws, refer to Figure 4.
4. Mark out location, then mount the bracket onto the wall using the 8 supplied screws. This bracket **MUST** have the hooks facing upward and be level.

NOTE: It is strongly recommended that the mounting bracket be screwed into the wall studs where possible. If the wall studs cannot be used, ensure that the supplied plastic anchors are used to affix the bracket to the wall and the bracket is adequately secured

5. With the wall mounting bracket installed have two people lift the appliance up and insert the two hooks on the bracket into the two slots on the back of the appliance.
6. Check the appliance for stability ensuring that the bracket will not pull free from the wall.

FIGURE 4



Bracket for JR42S/EF-WM502

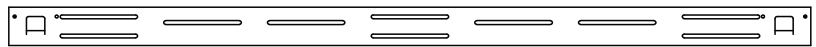

Bracket for JR50S/EF-WM503 and JR60S/EF-WM504

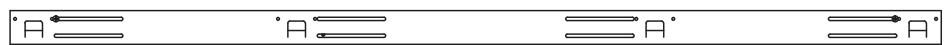

Bracket for JR-72S/EF-WM505

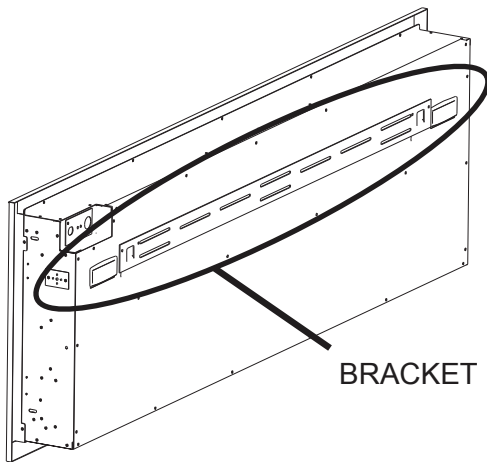

BRACKET

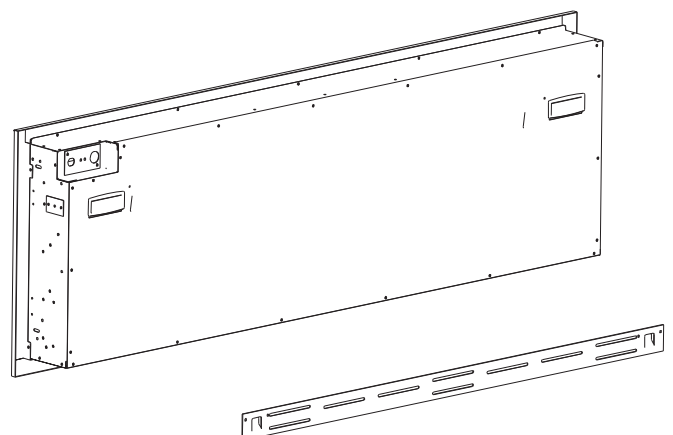
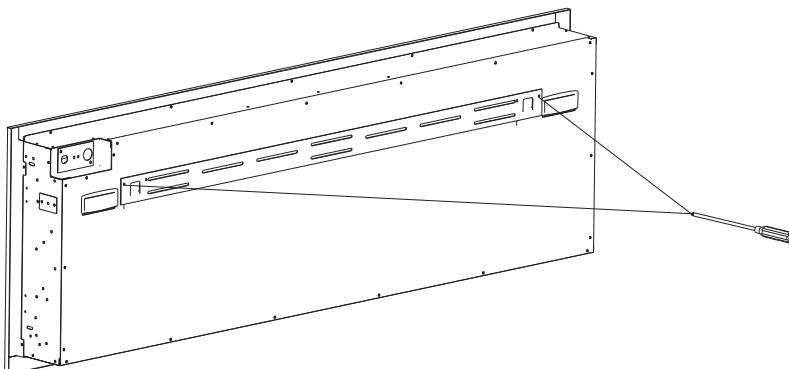

Option 2: Recessing the Appliance Flush into the Wall

Due to the many different finish materials used on walls, it is highly recommended that you consult your local builder before you install this appliance in the wall.

Select a location that is not prone to moisture and is located at least 36" (914mm) away from combustible materials such as curtain drapes, furniture, bedding, paper etc.

1. Measure the appliance and create a rough in with electrical.
2. Hold the appliance up to ensure it will fit into the framing.
3. Remove the front glass (refer to Pages 14 for instructions).
4. Adjust the 4 oblong installation holes on both sides in the upper and lower corner of the firebox. Use the wood screws to mount and secure the firebox to the wood frame.

NOTE: The slim design of our units allow them to fit in 2 x 4 framing up to 2 x 8 framing.



TOP VIEW

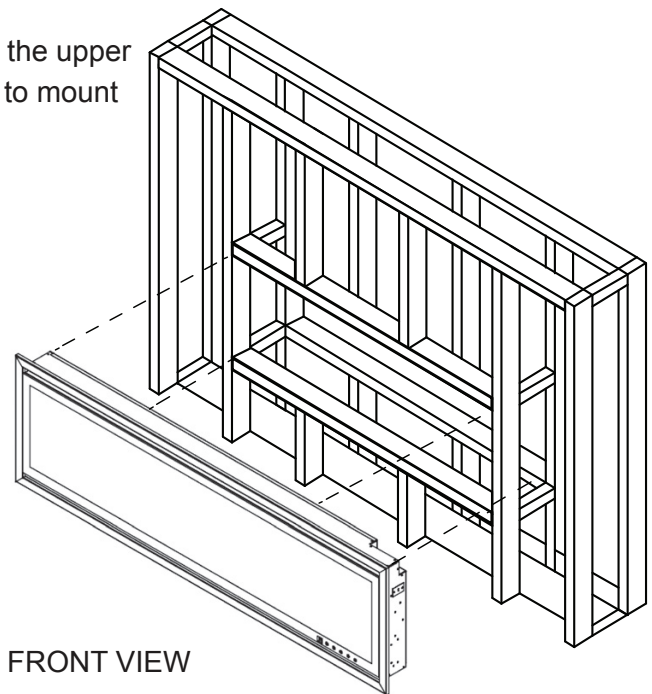

FRONT VIEW

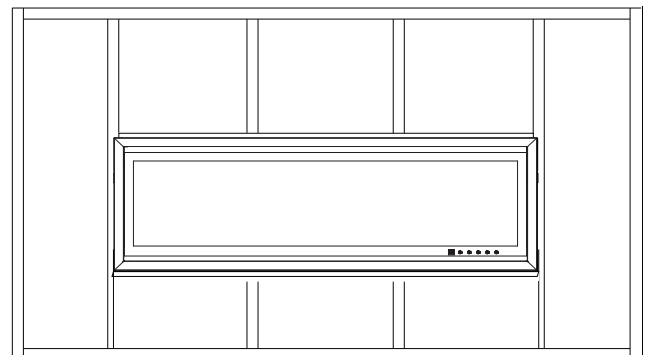

Minimum Clearance to Combustibles

Measurements are taken from the glass front	
Sides, back and top	0"

Framing for Recessed in Wall Installation Options

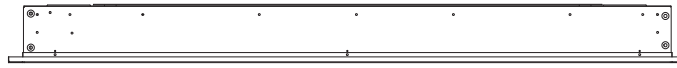

TOP VIEW

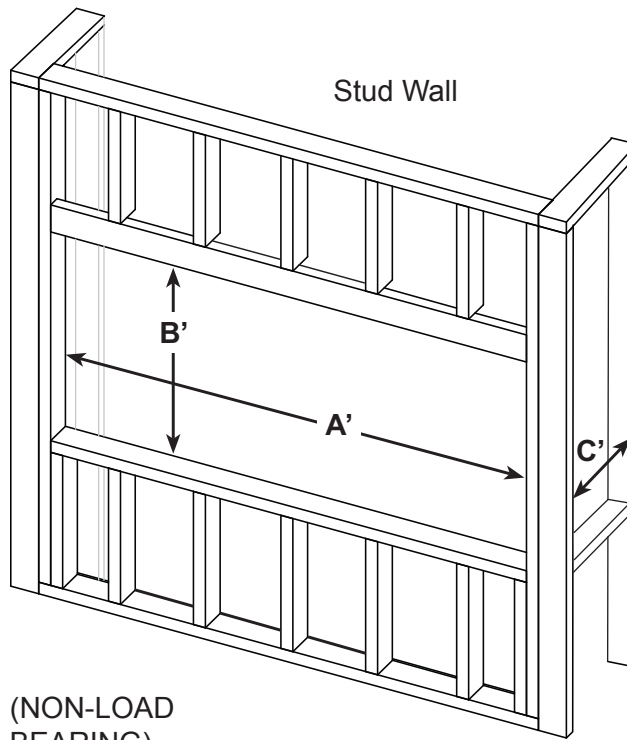

(NON-LOAD BEARING)

Item No.	A	B	C Firebox with trim width	A' (opening)	B' (opening)	C' Firebox without trim width + 0.5" opening
EF-WM502	47"	18.3"	4.6"	45.4"	17"	4.6"
EF-WM503	55"	18.3"	4.6"	53.4"	17"	4.6"
EF-WM504	65"	18.3"	4.6"	63.4"	17"	4.6"
EF-WM505	77"	18.3"	4.6"	75.4"	17"	4.6"

NOTE to installer: A', B', and C' are the suggested opening dimensions for installing the firebox into the frame wall. Dimensions are subject to the constructor's final confirmation.

Hard Wiring Installation

WARNING

TURN OFF THE APPLIANCE COMPLETELY AND LET COOL BEFORE SERVICING. ONLY A QUALIFIED SERVICE PERSON SHOULD SERVICE AND REPAIR THIS ELECTRIC APPLIANCE.

HARD WIRING CONNECTION

If it is necessary to hard wire this appliance, a qualified electrician must remove the cord connection, and wire the appliance directly to the house hold wiring. This appliance must be electrically connected and grounded in accordance with local codes.

1. Remove the cover plate from the left side of the appliance. Remove the two screws, as shown in FIGURE 1. Unscrew and remove power cord.

FIGURE 1

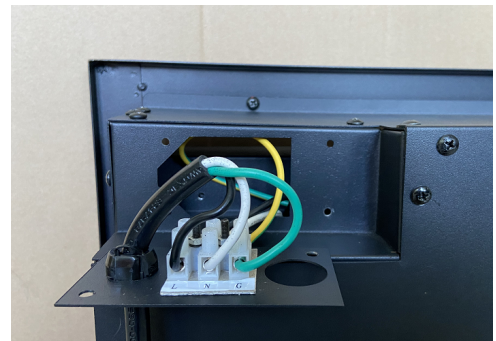
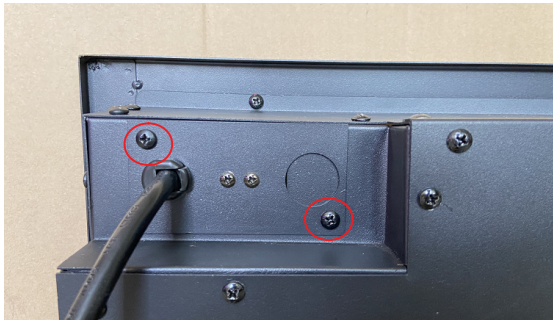

2. Attach the wiring to the wire connector. Please make sure the live wire (Black) goes into the "L", the neutral wire (White) goes into the "N" and the ground wire (Green) goes into the "G".

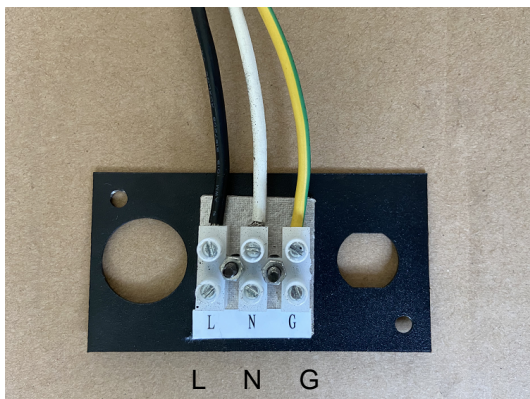

3. Replace the plate and reattach.

NOTE: Leave enough wire so that the appliance can be removed from the enclosure without disconnecting the power supply.

Wall Thermostat Installation

WARNING

TURN OFF THE APPLIANCE COMPLETELY AND LET COOL BEFORE SERVICING. ONLY A QUALIFIED SERVICE PERSON SHOULD SERVICE AND REPAIR THIS ELECTRIC APPLIANCE.

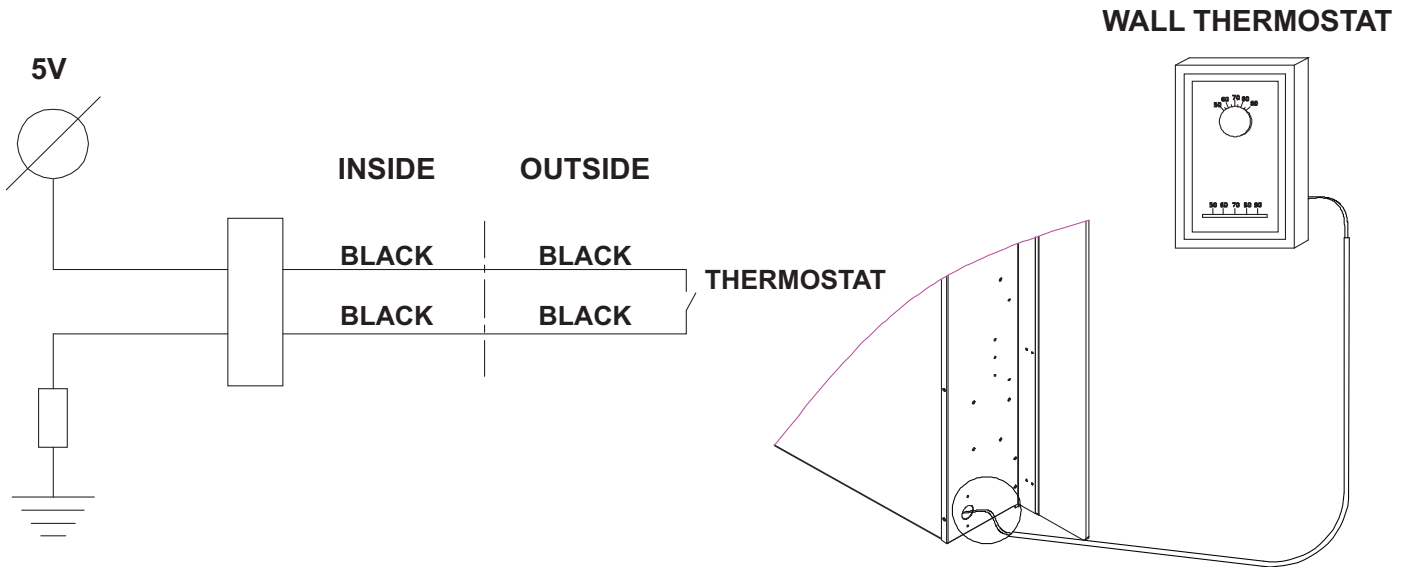

NOTE: Wire the wall thermostat prior to installing the fireplace

Wall Thermostat Wiring (24AWG)

1. Turn off circuit breaker.
2. Remove cover plate located on the left side of the appliance.
3. Pull the wire out and cut the inside thermostat. Connect the wires to the wall thermostat as shown below. Follow instructions provided with wall switch kit.



Front Glass Removal

1. Remove 4 screws on both sides. Remove front glass and place it in a secure location
2. Place the glass safely aside on a flat, smooth surface.

FIGURE 4

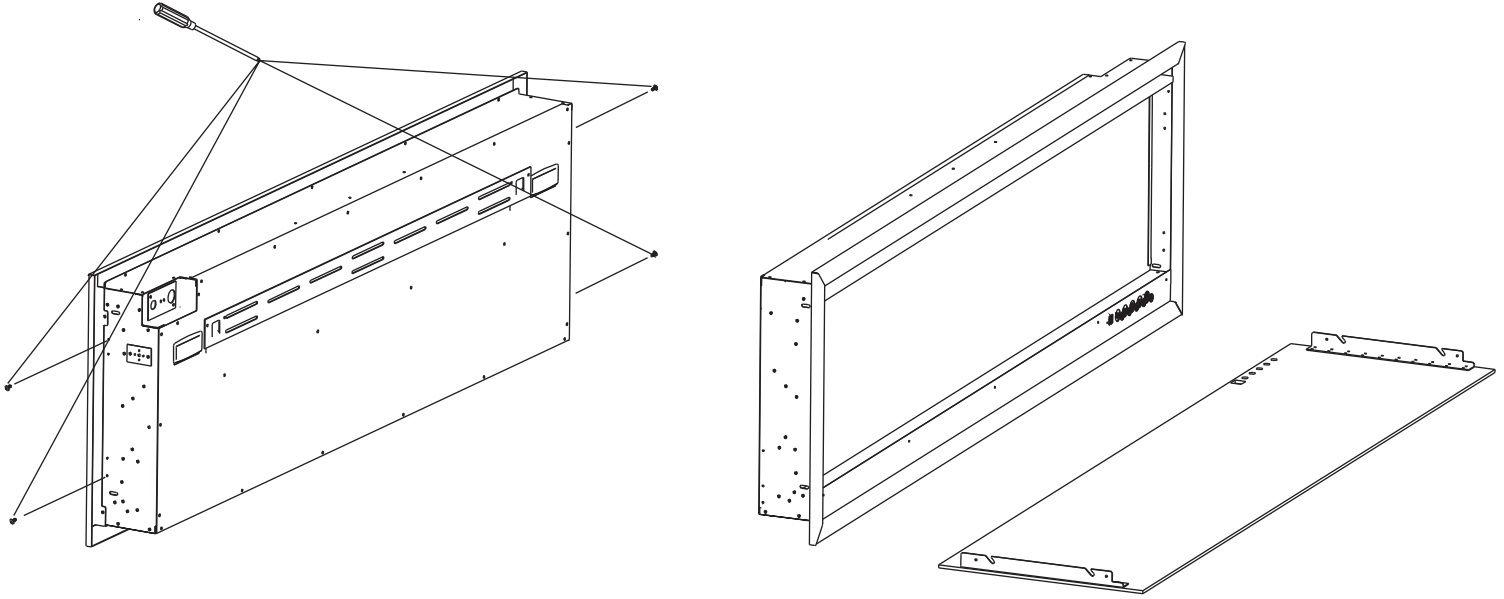

Crystal Embers and Wood Logs Installation

The glass front must be removed and the appliance must be secured in its final location before the crystal embers are installed.

1. Complete steps 1-2 in the “ Front Glass Removal” instructions.
2. Take out the front glass, unload/load the crystal and media onto the ember bed.
3. Replace front glass.

SIDE VIEW

FRONT VIEW

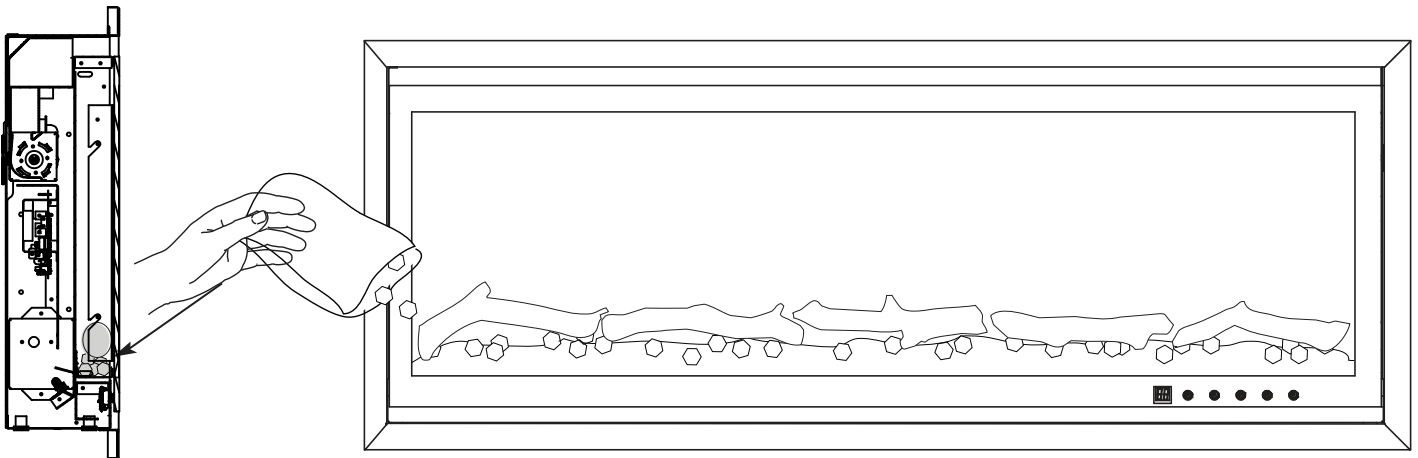

Operating Instructions

WARNING

WHILE THE APPLIANCE IS OPERATING DO NOT REMOVE THE GLASS PANEL. THIS WILL CAUSE THE REMOTE CONTROL TO DISFUNCTION.

Once the appliance has been plugged into a grounded electrical outlet, it is ready to operate.

NOTE: Ensure the house circuit breakers for the power supply are turned on. In the event of a power failure, the appliance will lose its memory function and will reset to factory mode when the power returns.

Main Power Switch

To turn unit power on:

1. Plug in power cord. If hard wired, just turn on the power switch on the unit.
2. Verify the power is turned on when two ring tones are initiated.

Operating with Touch Panel

The unit can be controlled by either the touch panel controls which are located on the lower right side of the front glass or the remote control.

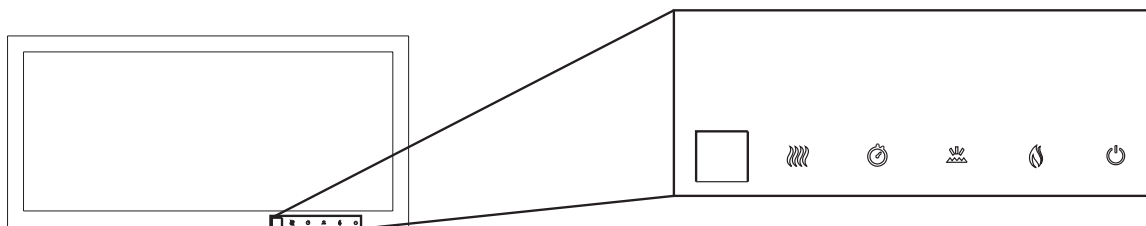

1. Ensure steps 1-2 in the "Main Power Switch" procedure are first followed.
2. Press the "🔴" button to turn on/off the fireplace; If turn on (indicate "ON"), the Red, blue and yellow flame (F4), ember bed (E3) LEDs at the brightest level. Press again, the heater is in OFF status indicate "OF", goes off after 5 seconds.
3. Press the "🔥" button multiple times to cycle through 4 different brightness levels and OFF for all the flames LED (Red, Yellow and Blue). Indicate (F4-F3-F2-F1-F0).
4. Press the "❄️" Multiple times to cycle through the ember bed colors of red, pink, snow white, cool blue, dark blue, green, lake green, all-colors automatic circulation (EE) in 30 seconds and OFF (E0). Indicate E1-E2-E3-E4-E5-E6-E7-EE-E0..
5. Press the "🕒" to activate the timer. Press once for 30 minutes. Each additional press adds 1 hour to a maximum of 8 hours. LED display shows 30-1H-2H-3H-4H-5H-6H-7H-8H-00
6. Press the "🌡️" button to set temperature level, press key for temperature setting, if room temperature is lower than temperature setting, two groups of heating system will turns ON (indicate current temperature setting); press until both the heating systems and the blower are OFF (indicate H0). Repeat circulation.
Celsius & Fahrenheit degree setting. Press and hold button for 3 seconds, interchange Celsius and Fahrenheit degree
C: H0-16-19-21-23-25-27-30. F: H0-61-66-70-73-77-80-86

Note: The touch panel buttons will glow when pressed. The light fades in 5 seconds after pressing.

WiFi APP Installation Procedure



Available for Android and iOS, the Smart Flame Connect app can be used to control your WiFi-enabled fireplaces. After installing the app follow these steps:

1. Create an Account

Create a profile to use the JR App, and connect your fireplace for convenient control: Ensure you have access to an email.

When the app starts, select “Register” and you will be prompted to enter your email. Once you’ve entered your email, press “Get Verification Code” and a secure login code will be sent to your email. Enter the code back in the JR Smart Flame Connect App to complete registration.

2. Fireplace WiFi Setup

- To begin WiFi setup, ensure the fireplace is plugged in and receives power. The fireplace will need to be in standby mode (plugged in, flame and heater off). The control buttons are located at the bottom right of the unit.
- Press and hold the Flame button for 5 seconds and release, the Flame Indicator will begin to flash, indicating the fireplace is ready to connect to WiFi.
- After Wifi connected, the flame indicator will stay ON, and will go OFF until the fireplace is power ON.

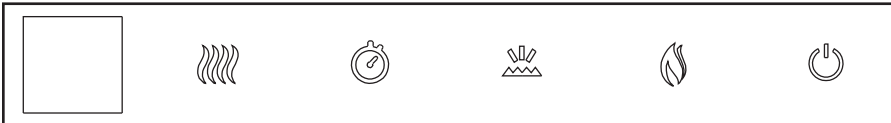

3. Check for Firmware Update

Before updating the fireplace’s firmware, please ensure you have a stable internet connection and the fireplace is powered on.

1. In the app, select the device you wish to update.
2. In the device control panel, select the settings icon on the top right, then select “Check for Firmware Update”. You will be prompted to start the update if available.

4. Controls via 4G/LTE Mobile Networks

To control the fireplace with your phone’s mobile network, you will need to connect the fireplace to your home WiFi and have registered for an account in the app. When your fireplace is connected to your home WiFi and your account, you can now have access to your fireplace even if you are not home.



iOS – Scan the QR code for JR Home Smart Flame Connect for Apple iOS

Android - Scan the QR code for JR Home Smart Flame Connect for Google Play

more help? <https://www.jrhome.com/app-smart-flame-connect-techsup/>

Multi-functional Operating with Remote Control

Turning ON/OFF the appliance:

1. Ensure steps 1-2 in the "Main Power Switch" procedure are first followed.
2. Press the "⏻" remote button to turn on the red, blue and yellow flame at the brightest level. Ember bed color is white. Indicate "ON" on LED display. The heater is in OFF status. Press again to turn off the fireplace. Indicate "OFF" on LED display. LED display for 5 seconds, then goes off.

Note: If power is not in OFF condition, shutdown by the remote control, then next time turn ON by the remote control, the existing setting will resume to the previous shutdown setting. The heater and timer is OFF

Changing LED, Timer and heating options:

1. Ensure steps 1-2 in "Turning ON/OFF the appliance" are previously followed.
2. Press the yellow "🔥" button multiple times to cycle through 4 different brightness levels and OFF for the yellow flame LEDs. Display shows y4, y3, y2, y1 or y0 for off.
3. Press the blue "🔥" button multiple times to cycle through 4 different brightness levels and OFF for the blue flame LEDs. Display shows b4, b3, b2, b1 or b0 for off.
4. Press the red "🔥" button multiple times to cycle through 4 different brightness levels and OFF for the red flame LEDs. Display shows r4, r3, r2, r1 or r0 for off.
5. Press the middle "🔥" button to turn on/off all flame colors and ember bed. If press off and on again, the LED setting will resume to previous setting. (F0) indicates all flame colors OFF, (FF) indicate all flame colors ON.

6. Press the "🔥" button multiple times to cycle through the colors of red (E1), pink (E2), snow white (E3), cool blue (E4), dark blue (E5), green (E6), lake green (E7), OFF (E0). and all-color automatic circulation (each color changing after 30 seconds) (EE).

7. Press the "🔥" button, heater ON/OFF. Press once, the heater is ON, "HIGH" temperature status with 2 groups of heating system turned ON at 1500W; press again, the heater is OFF.

Press button for 5 seconds (heater lock/unlock function), the heater and related keys will lock, displays "LO"; press the key again for 5 seconds, the heater will unlock, displays "UL". You will hear a "beep" sound when keys are pressed, but but can't turn on and no response; if heater is in ON position, press "lock", the heater will turn off, and related temperature keys will lock and not response, only hear "beep" sound when press again. After heater and related keys are locked, the flame and lighting will remain ON and controllable. If we press the key again for 5 seconds, the heater will unlock, and the heater is in OFF position, until user press any heating function. If heater is ON, while flame lighting is OFF, indication will display heater current setting (H1 or H2) and will not disappear, until flame lighting resumed.

8. To set temperature level, press "🌡️" for temperature setting, if room temperature is lower than temperature setting, two groups of heating system will turn ON (indicate current temperature setting); press until both the heating systems and the blower are OFF (indicate H0). NOTE: Celcius is the default temperature setting. The parameters is pre-set in degrees Celsius 16-19-21-23-25-27-30; Repeat circulation. Press "🌡️" key for 5 seconds, hear a "beep" sound once, the indication will display "F" for 3 seconds. and disappear, (indicate that Celsius degree has been changed to Fahrenheit degree). Celsius degree is switched to associate Fahrenheit degree; the parameter is set to Fahrenheit degree of 61-66-70-73-77-80-86. Temperature key only function when heater is ON.
9. Press the "📊" button, the heater turns on in LOW (H1) (750W).
10. Press the "📊" button, the heater turns on in HIGH (H2) (1500W).
11. Press the "🔄" to preset the desired flame effect and one button return to preset stage. Press the key for 3 seconds to memorize the flame setting. When you want to return to preset stage, press the key once. Only 1 memorized flame setting saves, so any new setting will override the previous setting. Indicator shows "PS".
12. Press the "🕒" to activate the timer. Press once for 30 minutes. Each additional press adds 1 hour to a maximum of 8 hours. LED display shows 30-1H-2H-3H-4H-5H-6H-7H-8H-00



Remote Control Specification

1. Model: R302
2. Remote Key: 12
3. Communication: Infrared
4. Infrared Distance: 6 Meters
5. Battery: AA x 2pcs

NOTE: Make sure your “AA” batteries (x2) are fully charged and installed correctly in your remote control before operating.

The remote control must remain within 6 meters of the appliance to be effective, this range may be reduced when battery power is depleted.



Maintenance

WARNING

PREPARATION FOR MAINTENANCE

ALWAYS DISCONNECT THE POWER AND ALLOW THE ELECTRIC APPLIANCE TO COOL BEFORE PERFORMING ANY CLEANING, MAINTENANCE OR RELOCATION OF THIS ELECTRIC APPLIANCE. TURN CONTROLS TO OFF AND REMOVE PLUG FROM OUTLET OR TURN OFF THE HOUSE CIRCUIT BREAKER TO ELECTRIC APPLIANCE RECEPTACLE.

DO NOT INSTALL LED LIGHT STRIPS THAT EXCEED SPECIFIED MAXIMUM WATTS.

THE LED LIGHT STRIPS IN YOUR APPLIANCE CAN BECOME EXTREMELY HOT. ALLOW AT LEAST 10 MINUTES BETWEEN TURNING OFF THE APPLIANCE AND REMOVING THE STRIPS TO AVOID ACCIDENTAL BURNS.

DO NOT HANDLE THE LED LIGHT STRIPS WITH BARE FINGERS. USE GLOVES OR A CLEAN DRY CLOTH WHEN HANDLING.

Storage Instructions

Ensure the power cord is not installed so that it is pinched or against a sharp edge and ensure that the power cord is stored or secured to avoid tripping or snagging to reduce the risk of fire, electric shock, or injury to persons.

Construction and electrical outlet wiring must comply with local building codes and other applicable regulations to reduce the risk of fire, electrical shock, and injury to persons.

Do not attempt to wire your own new outlets or circuits. To reduce the risk of fire, electric shock, or injury to persons, always use a licensed electrician.

Wiring Diagram: Standard Model



WARNING

TURN OFF THE APPLIANCE COMPLETELY AND LET COOL BEFORE SERVICING. ONLY A QUALIFIED SERVICE PERSON SHOULD SERVICE AND REPAIR THIS ELECTRIC APPLIANCE.

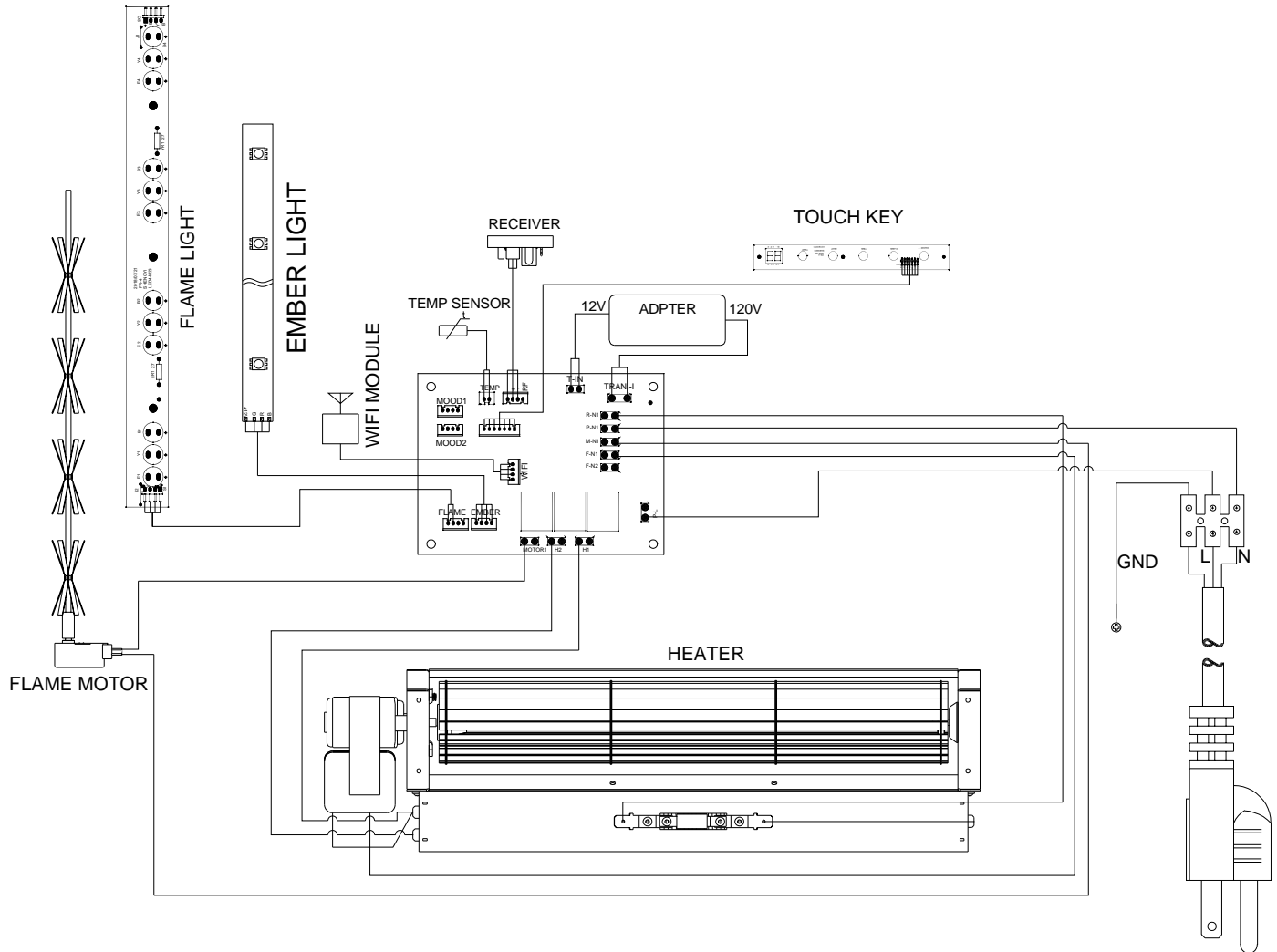

Replacement Parts



WARNING

FAILURE TO POSITION THE PARTS IN ACCORDANCE WITH THIS MANUAL OR FAILURE TO USE ONLY PARTS SPECIFICALLY APPROVED WITH THIS APPLIANCE MAY RESULT IN PROPERTY DAMAGE OR PERSONAL INJURY.

To order parts, contact customercare@jrhome.com

FOR WARRANTY REPLACEMENT PARTS, A PHOTOCOPY OF THE ORIGINAL INVOICE WILL BE REQUIRED TO HONOUR THE CLAIM.

When ordering replacement parts always give the following information:

- Model and serial number of appliance
- Installation date of appliance
- Part reference number
- Description of part
- Finish

FOR FURTHER INFORMATION, CONTACT YOUR AUTHORIZED DEALER.

COMPONENTS

Ref.	Part Description	JR-42S	JR-50S	JR-60S	JR-72S
1	Front glass	FG42	FG50	FG60	FG72
2	Flame PP board	PP42	PP50	PP60	PP72
3	Touch panel circuit board	RA8-1M	RA8-1M	RA8-1M	RA8-1M
4	Flame system flicker rod	RB42	RB50	RB60	RB72
5	LED circuit board	FLDXX	FLDXX	FLDXX	FLDXX
6	Main circuit board	DHSJ-LRC29-01-06	DHSJ-LRC29-01-06	DHSJ-LRC29-01-06	DHSJ-LRC29-01-06
7	Heater/Blower system	FRT30-306	FRT30-306	FRT30-306	FRT30-306
8	Flame motor	120v/10/12rpm	120v/10/12rpm	120v/10/12rpm	120v/10/12rpm
9	Power adapter	XY60S-1205000Q-UF	XY60S-1205000Q-UF	XY60S-1205000Q-UF	XY60S-1205000Q-UF
10	Remote control	R302	R302	R302	R302
11	Remote control receiver	301506	301506	301506	301506
12	Crystals	300g	540g	540g	540g
13	Wall mount bracket	3184021	324013	324013	328015
14	Log Set	42LOG	42LOG	42LOG	72LOG
15	Hardware Pack	42SCREW	50SCREW	50SCREW	72SCREW

Replacement Parts Diagram

WARNING

FAILURE TO POSITION THE PARTS IN ACCORDANCE WITH THIS MANUAL OR FAILURE TO USE ONLY PARTS SPECIFICALLY APPROVED WITH THIS APPLIANCE MAY RESULT IN PROPERTY DAMAGE OR PERSONAL INJURY.

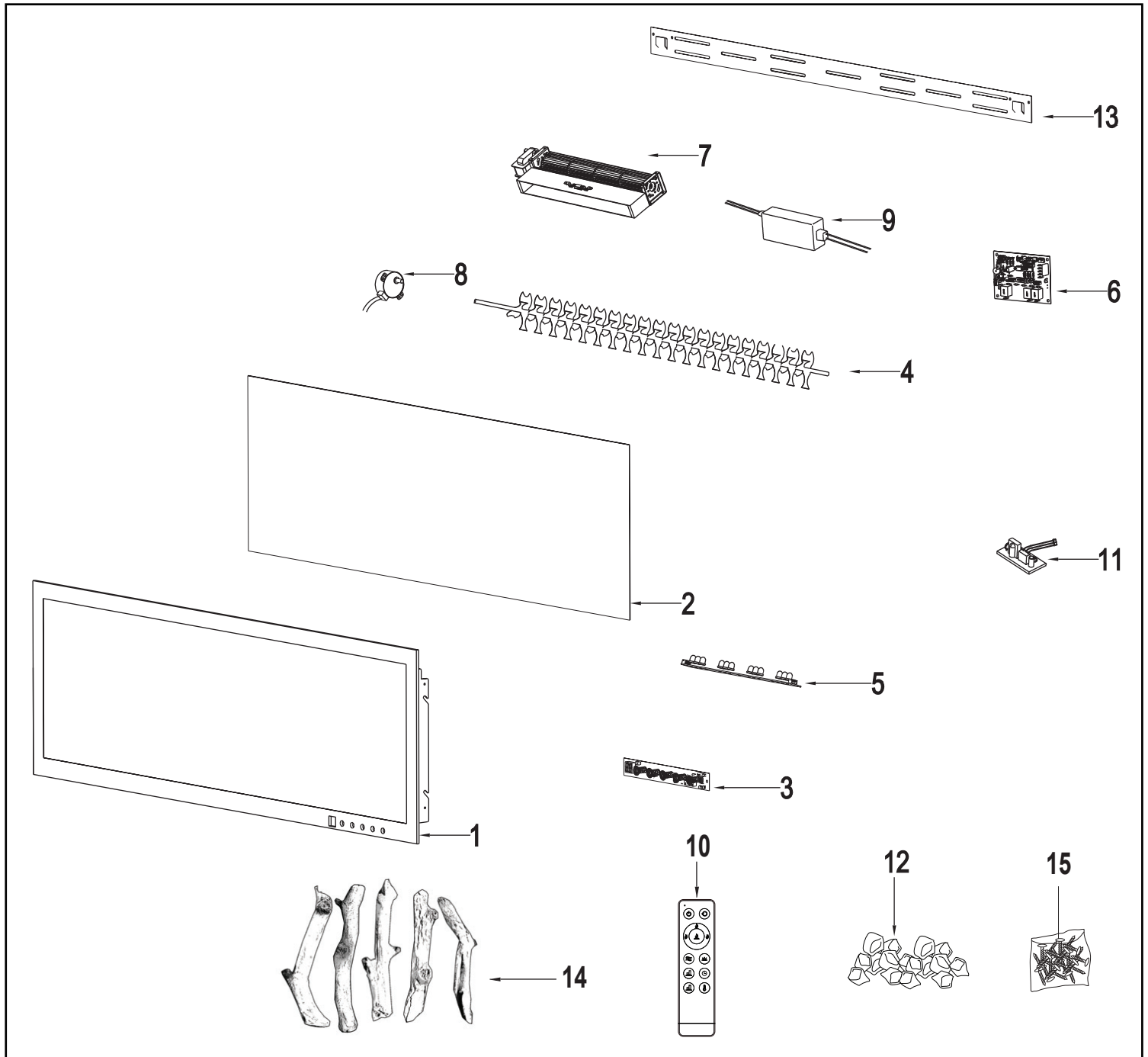

NOTE: Care must be taken when removing and disposing of any broken glass or damaged components. Be sure to vacuum up any broken glass from inside the appliance before operation.

Troubleshooting

WARNING

TURN OFF THE APPLIANCE COMPLETELY AND LET COOL BEFORE SERVICING. ONLY A QUALIFIED SERVICE PERSON SHOULD SERVICE AND REPAIR THIS ELECTRIC APPLIANCE.

Symptom	Potential Cause	Solution
Abnormal noise	From heater assembly (item 7)	Blower assembly has a defect that is causing noise during high speed rotation. Replace the whole heater assembly
	From flame flicker rod assembly (item 4) a. Repeating clicking sound during flame operation b. Scratching noise during flame operation	Flicker rod (item 4) curved when hitting/ rubbing the flame wall (item 2) and back wall during rotation that cause the noise. If flicker rod is slightly curved, pull out the flame board/flame pattern (which is thin metal) to adjust the depth between the flicker rod and the flame board.
	Noise from flame flicker rod assembly motor.	Lack of lubricant or defect. Replace the motor.
	Internal wiring is losing and fall in between the flicker rod and the back wall that cause the friction noise.	Re-wire and fix the wiring to prevent the wiring from falling.
Heater not blowing	Motor from heater assembly	If motor is not working, the blower doesn't rotate, it will cause the heater overheated. Turn off and unplug the fireplace. Replace the whole heater assembly.
Flame not rotating (e.g. Flame is not moving smoothly or stop moving)	Motor from flame flicker rod system (item 4)	The flame LED is ON, but not rotating. Replace the motor on the flame flicker rod.
Appliance turns off and will not turn on	Appliance has overheated and safety thermal switch has tripped	Unplug power cord and allow appliance to cool for 15 minutes, then plug in the power cord and turn the power ON
	House circuit breaker has tripped	Reset house circuit breaker
The fireplace does not connect to WiFi network	Connection problems between the modem and the fireplace	a) relaunch the application and try again b) turn off/on the fireplace's main power c) reboot the network modem

Troubleshooting

Symptom	Potential Cause	Solution
Dim or no flame / Ember bed / Ceiling light is not glowing or dimming	Flame LED's are burnt out or wire loosing	Inspect the LED's and replace them if necessary
	Ember bed LED's are burnt out or wire loosing	Inspect the LED's and replace them if necessary
	Ceiling Light LED's are burnt out or wire loosing	Inspect the LED's and replace them if necessary
	Main circuit board burnt out or wire loosing	Inspect the Main circuit board and replace if necessary
No warm air coming out of appliance	Room temperature is higher than the appliance setting (if it is set to room temperature)	Reset temperature setting
	Heater is locked out	Unlock heater. See operation section
	Heater is burnt out	Inspect the heater assembly and replace it if necessary
Appliance turns off and will not turn on	Appliance is not plugged into an electrical outlet or the hard wire connections are not correct (if applicable)	Check plug and plug it into a 120V outlet. Check the hard wire connections (if applicable)
	Appliance has overheated and safety thermal switch has tripped	Unplug power cord and allow appliance to cool for 15 minutes, then plug in the power cord and turn the power ON
	Circuit board is burnt out	Inspect the circuit board and replace it if necessary
Remote control does not work	Low battery	Replace batteries in remote control
Heater shuts off automatically	Room is too warm	The heater has a built-in thermostat so it will shut off automatically once the pre-set temperature is reached. It will also turn on automatically if the room temperature drops below the pre-set temperature.
Touch panel/ Remote Control do not work	The front glass has moved or is not secured properly	Unplug the appliance, if the appliance is recessed into the wall, shut off house circuit breaker. Ensure the front glass is in the correct position and is sitting flat to the appliance touch panel. After 10 seconds, plug in or turn on the appliance to reset it.

IMPORTANT

For questions, concerns or problems with our product please email our customer service department:

customercare@jrhome.com

DATED PROOF OF PURCHASE REQUIRED FOR WARRANTY SERVICE

Si vous éprouvez des difficultés, ou si vous avez des questions ou des préoccupations, prière de faire parvenir un courriel à notre Service à la clientèle

customercare@jrhome.com

UNE PREUVE D'ACHAT DATÉE EST REQUISE POUR SE PRÉVALOIR DE LA GARANTIE.

WARRANTY

This product is inspected, tested and carefully packaged to minimize the chance of damage during shipment. If a part (excluding light bulbs, glass and fuses*) within one year from the date of purchase proves to be defective in material or fabrication under normal use, the part will be repaired or replaced. The Company's obligation under the warranty is to replace or repair defective parts at our discretion. Any expenses or damage resulting from the installation, removal or transportation of the product will be the responsibility of the owner and are not covered by this warranty. The owner assumes all other risks arising from the use or misuse of the product. The warranty will be void if the product damage or failure is deemed by the Company to be caused by accident, alteration, misuse, abuse, incorrect installation or removal, or connection to an incorrect power source by the owner. The Company neither assumes, nor authorizes any person or entity to assume for it any obligation or liability associated with its products. Light bulbs and fuses are not covered under this warranty. If you have any questions regarding the warranty or service, please contact us at **customercare@jrhome.com**

Customer Service:

JR Home Products

Unit 306 - 19100 Airport Way, Pitt Meadows, BC V3Y 0E2

Toll Free: 1-800-561-5550

E-mail: **customercare@jrhome.com**

AVERTISSEMENT

Ce produit a été soigneusement inspecté, testé et emballé afin de minimiser les risques de dommages durant le transport. Si l'une des pièces (à l'exception des ampoules électriques verre et des fusibles*) s'avère défectueuse au niveau de sa fabrication ou de ses matériaux dans l'année qui suit la date de l'achat, suite à une utilisation normale, la pièce sera réparée ou remplacée. La Compagnie est tenue de réparer ou remplacer les pièces défectueuses, à sa discrétion, en vertu de la garantie. Tout frais ou dommage résultant de l'installation, du démantèlement ou du transport du produit demeure la responsabilité du client et n'est pas couvert par cette garantie. Le client assume tout autre risque résultant de l'utilisation, correcte ou fautive, du produit. La garantie devient nulle si la Compagnie détermine que le dommage ou le mauvais fonctionnement est causé par un accident, une modification, une mauvaise utilisation, un abus, une mauvaise installation ou un mauvais démantèlement ou un branchement à une source électrique inadéquate de la part du client. La Compagnie n'est pas responsable et n'autorise quiconque, personne ou entité légale, à accepter de responsabilité ou obligation en son nom, en rapport avec ses produits. * Les ampoules électriques et les fusibles ne sont pas couverts par cette garantie. Pour toute question en rapport avec la garantie ou le service, envoyez-nous un courriel à: **customercare@jrhome.com**.

Service à la clientèle :

JR Home Products

Unit 306 - 19100 Airport Way, Pitt Meadows BC V3Y 0E2

Toll Free: 1-800-561-5550

E-mail: **customercare@jrhome.com**

You MUST register your product to receive warranty service.

**Registration can be completed online at
www.jrhome.com or by mailing this form.**

Vous DEVEZ enregistrer votre produit pour vous prévaloir de la garantie.

**L'enregistrement sera complet une fois que vous
aurez posté ce formulaire ou s'inscrire en ligne à:**

Warranty Registration Information Form / Formulaire d'enregistrement de la garantie

Name / Nom: _____

Street / Adresse: _____

City / Ville: _____

Province / Province: _____

Postal Code / Code postal: _____

Daytime Phone # / No téléphone jour: _____

Evening Phone # / No téléphone soir: _____

E-Mail Address / Courriel: _____

Product/Produit: _____

Place of Purchase / Lieu de l'achat: _____

Date of Purchase / Date de l'achat: _____

Model # / No de modèle: _____

Serial # / Numéro de série: _____

You MUST register your product to receive warranty service.

For warranty service, contact J&R Home Products at the address, phone numbers listed below within 30 days of purchase. Be sure to have your sales receipt and original date of purchase. All warranty service will be coordinated by J&R Home Products service center.

Vous DEVEZ enregistrer votre produit pour vous prévaloir de la garantie.

Afin de faire valoir la garantie, communiquez avec J&R Home Products à l'adresse et aux numéros indiqués ci-dessous dans les 30 jours suivant la date d'achat. Ayez en main votre reçu et la date d'achat. Toutes les demandes liées aux garanties seront traitées par le centre de service de J&R Home Products.